

**DEVELOPMENT SITE**

**WEST STREET**

**STEWARTSTOWN**

**DUNGANNON**

**CO. TYRONE**

**BT71 5HT**

**TOM**

**HENRY**

**&CO.**

estate agents

*working harder to make your **move easier***

26 Church Street,  
Dungannon,  
Co. Tyrone,  
N. Ireland  
BT71 6AB

T: (028) 8772 6992  
F: (028) 8772 6460  
E: tom@tomhenryandco.com

**DEVELOPMENT SITE WITH FULL PLANNING PERMISSION FOR 51 DWELLINGS**

THIS EXCEPTIONALLY WELL LOCATED SITE IS IDEALLY LOCATED CLOSE TO ALL BUSTLING & POPULAR STEWARTSTOWN VILLAGE AMENITIES.

BENEFITTING FROM FULL PLANNING PERMISSION (**LA09/2020/1306/F**) FOR NO. 51 DWELLINGS ON 4.2 ACRES IT AFFORDS THE DISCERNING PURCHASER A "READY TO GO" OPPORTUNITY TO BUILD HOUSES IN THIS IN-HIGH-DEMAND LOCATION.

AN ADDITIONAL 1.2 ACRES (ADJACENT) IS ZONED AS RESIDENTIAL & IS ALSO AVAILABLE FOR PURCHASE.

**PROPOSED HOUSE TYPES. MAP FOR I.D. PURPOSES & SITE LAY OUT ATTACHED.**



**GUIDE PRICE: OPEN TO OFFERS**

PLANNING LEGISLATION, FLOOR PLANS AND SITE LAYOUT OVERLEAF...

**[www.tomhenryandco.com](http://www.tomhenryandco.com)**

## HOUSE TYPES:

HOUSE TYPE:	NUMBER OF UNITS:	HOUSE SIZE:
A	4	1200 SQ FT
B	5	960 SQ FT
B1	5	970 SQ FT
C	3	1310 SQ FT
C1	2	1310 SQ FT
C2	8	1310 SQ FT
D	3	1410 SQ FT
D1	4	1410 SQ FT
E1	6	1330 SQ FT
G	4	1130 SQ FT
G1	2	1130 SQ FT
H	1	775 SQ FT
E1	4	1110 SQ FT





**HOUSE TYPE A**

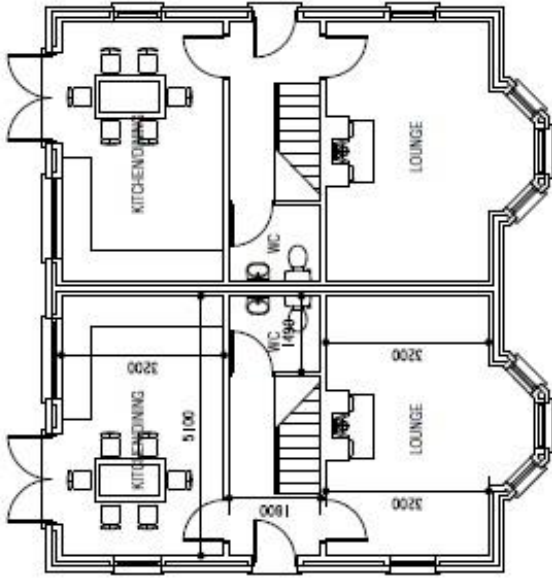

PROPOSED GROUND FLOOR PLAN

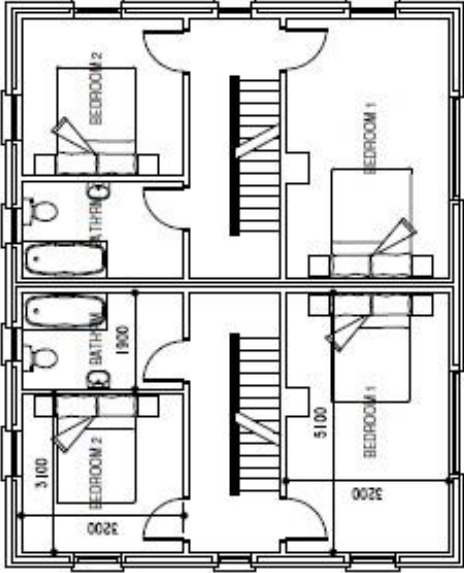

PROPOSED FIRST FLOOR PLAN

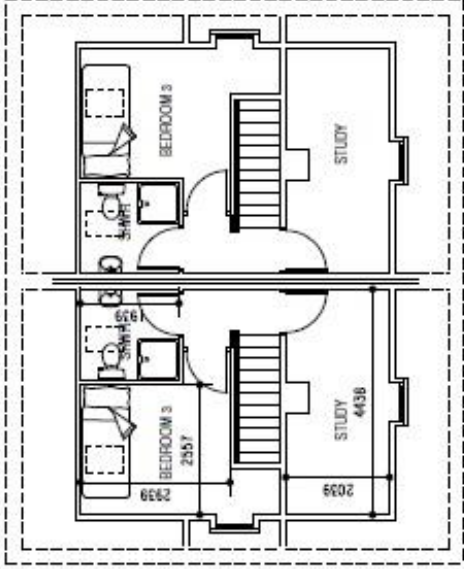

PROPOSED SECOND FLOOR PLAN

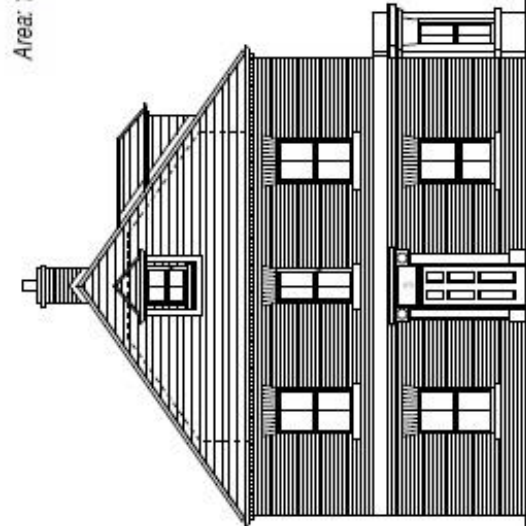

PROPOSED SIDE ELEVATION

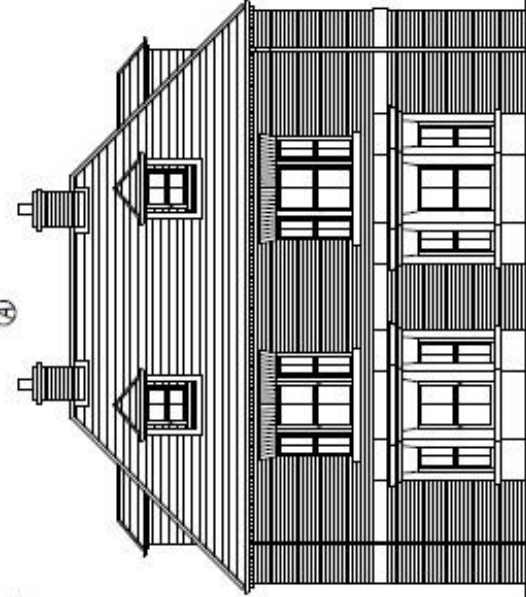

PROPOSED FRONT ELEVATION

BLACK ROOF TILES,  
RED/BROWN FACING BRICK,  
WHITE UPVC WINDOWS.

Area: 1200sqft

Ⓐ

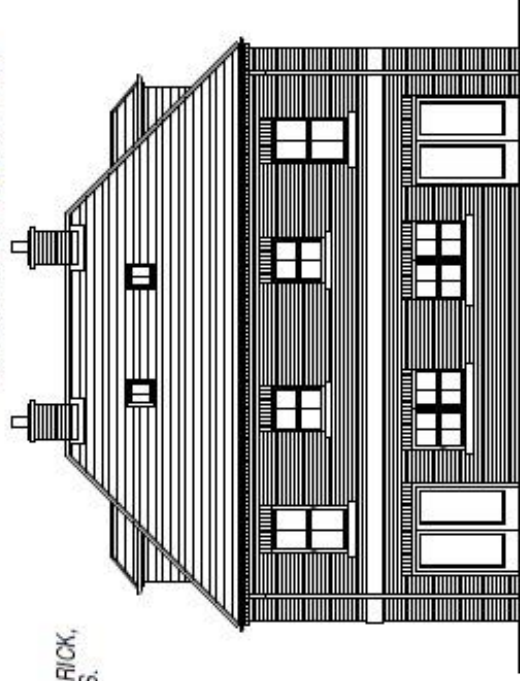

PROPOSED REAR ELEVATION

# HOUSE TYPE B & B1

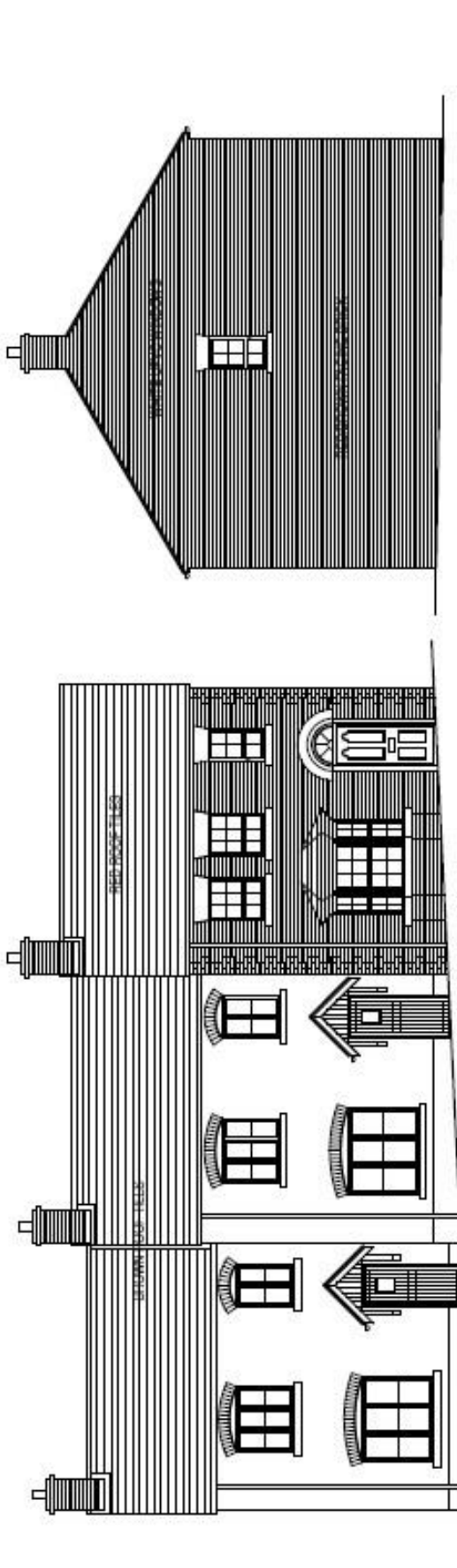

PROPOSED SIDE ELEVATION

PROPOSED FRONT ELEVATION

Area: 960sqft

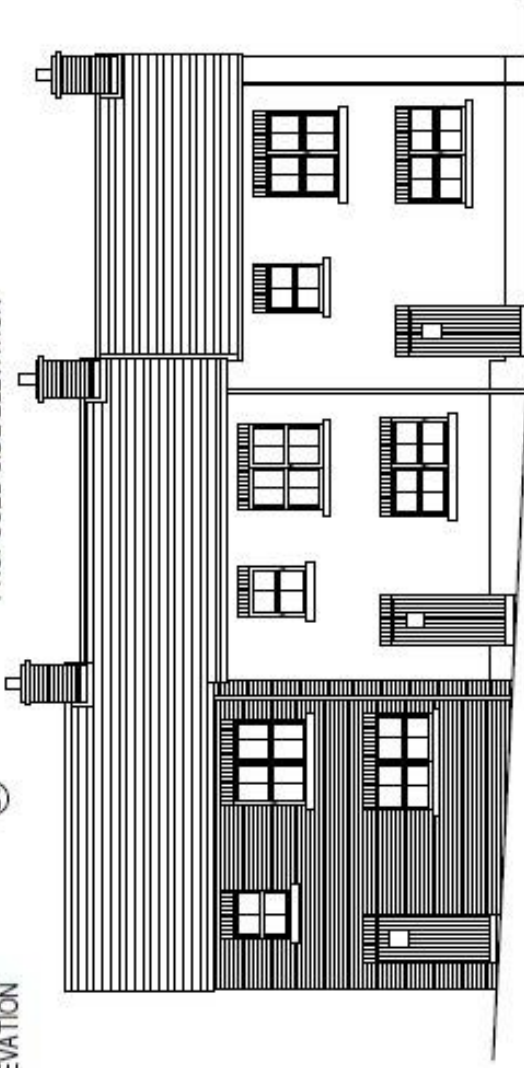
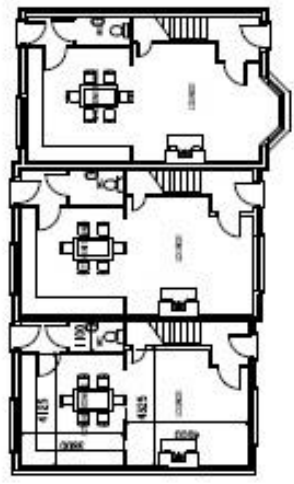
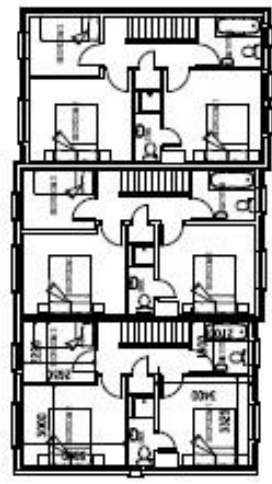

PROPOSED REAR ELEVATION

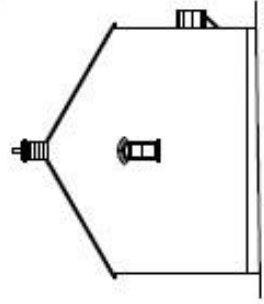

PROPOSED SIDE ELEVATION

PROPOSED GROUND FLOOR PLAN

**HOUSE TYPE C & C2**

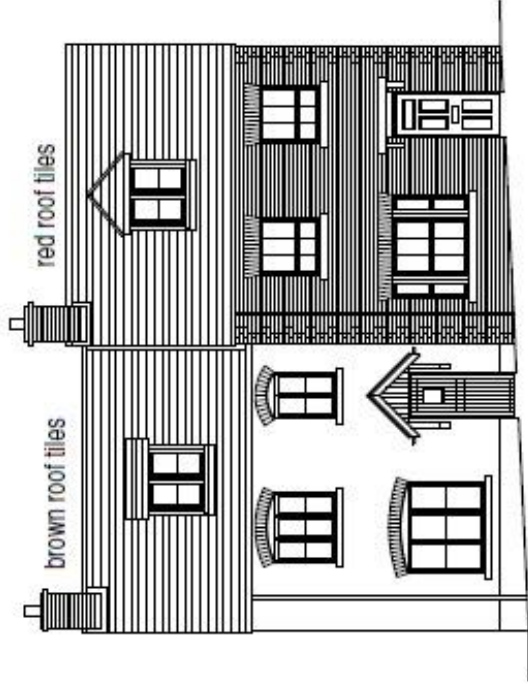

cream rendered walls  
red/brown facing brick  
**PROPOSED FRONT ELEVATION**

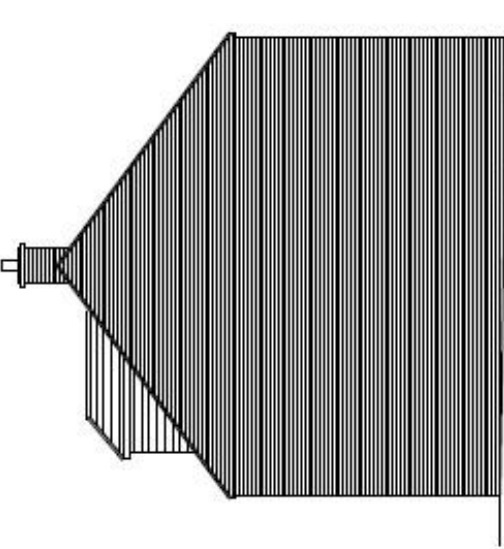

**PROPOSED SIDE ELEVATION**

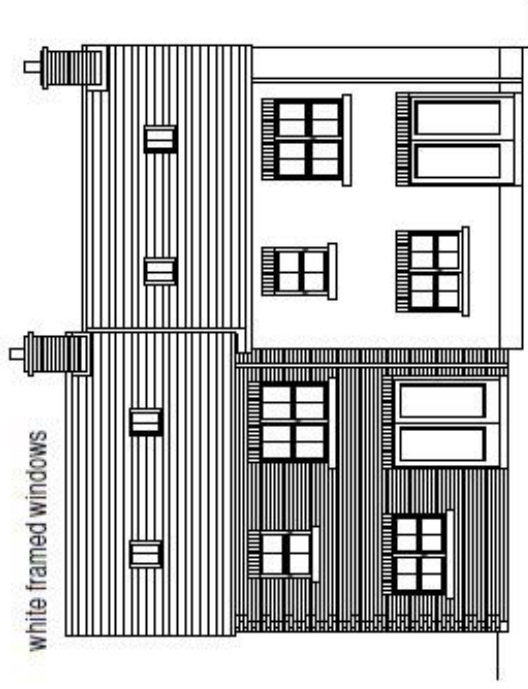

white framed windows

**PROPOSED REAR ELEVATION**

**C**

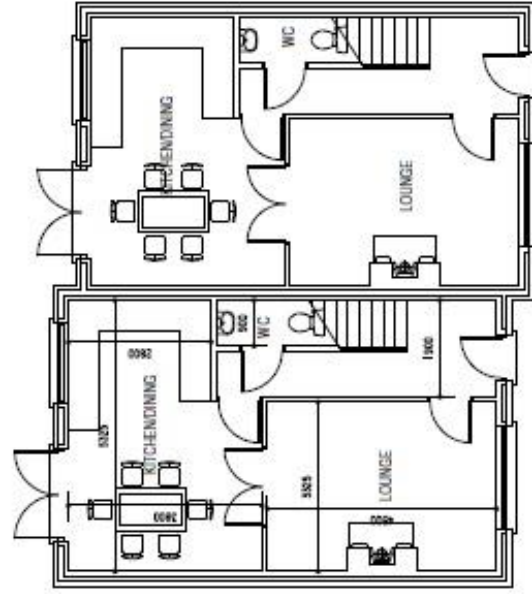

**PROPOSED GROUND FLOOR PLAN**

**C2**

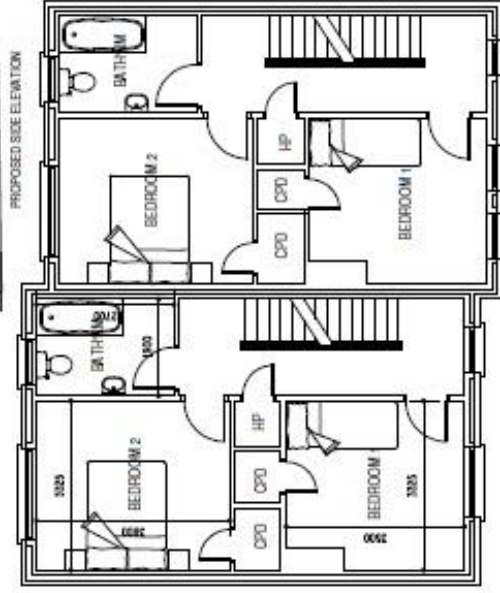

**PROPOSED FIRST FLOOR PLAN**

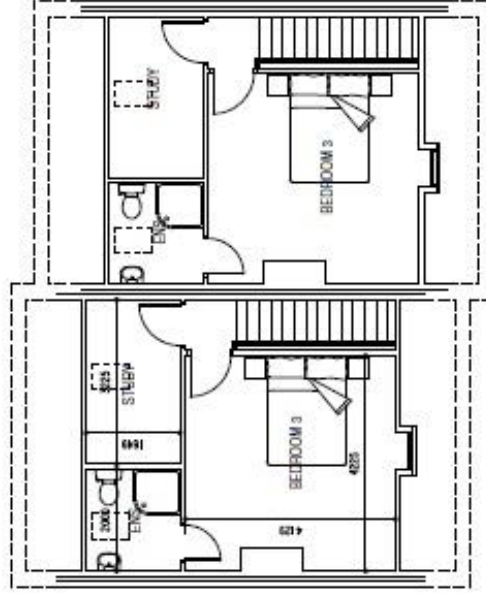

**PROPOSED SECOND FLOOR PLAN**

**HOUSE TYPE C2 & D1**

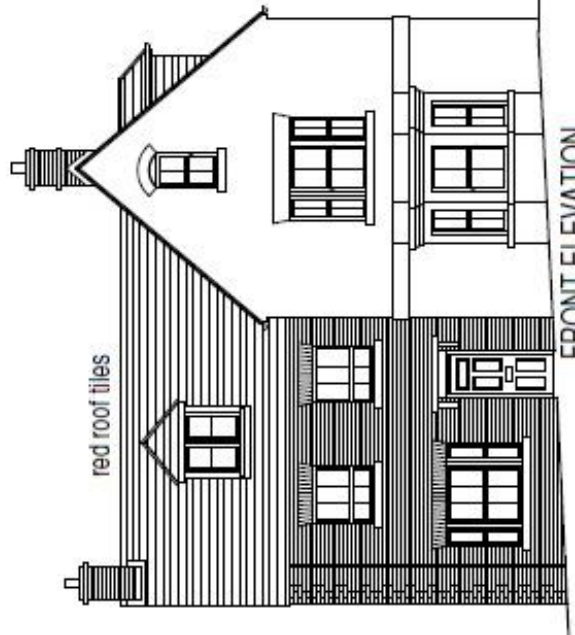

FRONT ELEVATION

red/brown facing brick

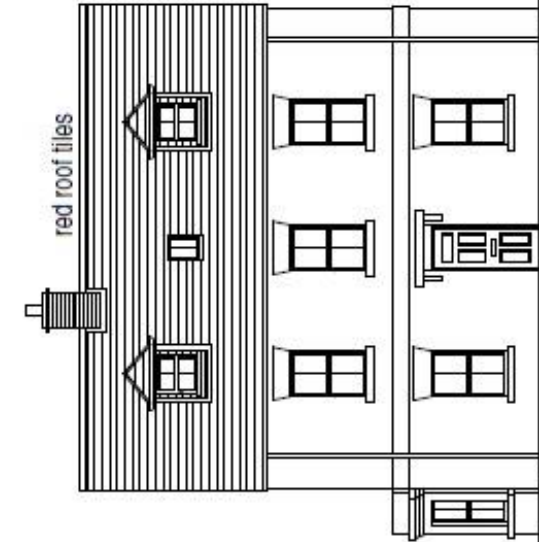

SIDE ELEVATION

white rendered walls

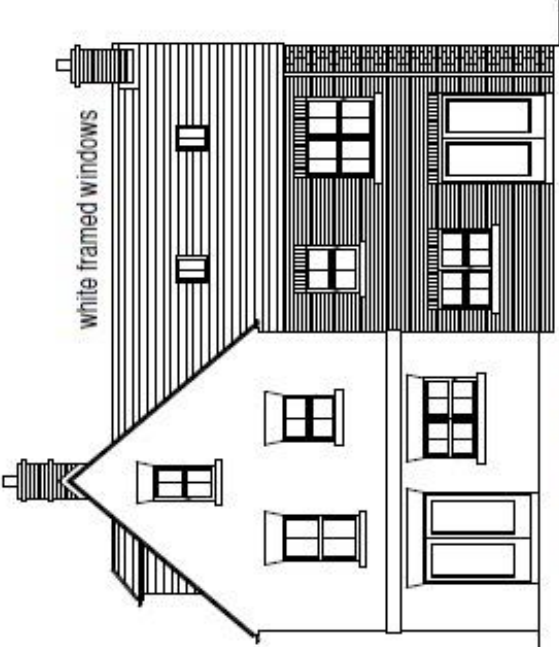

REAR ELEVATION

(C2)

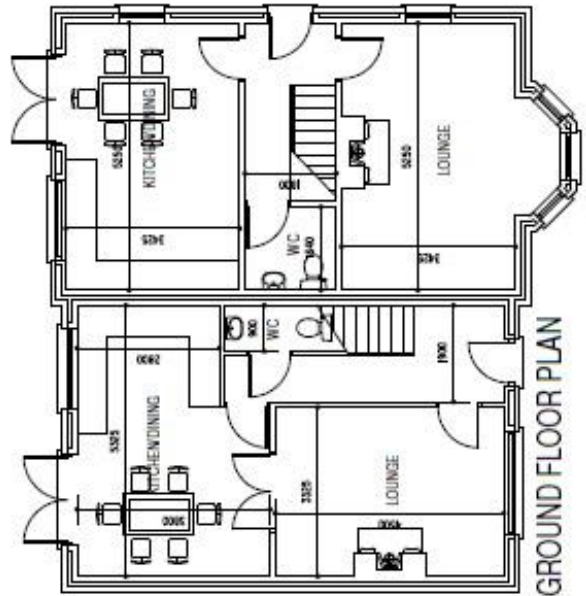

GROUND FLOOR PLAN

(D1)

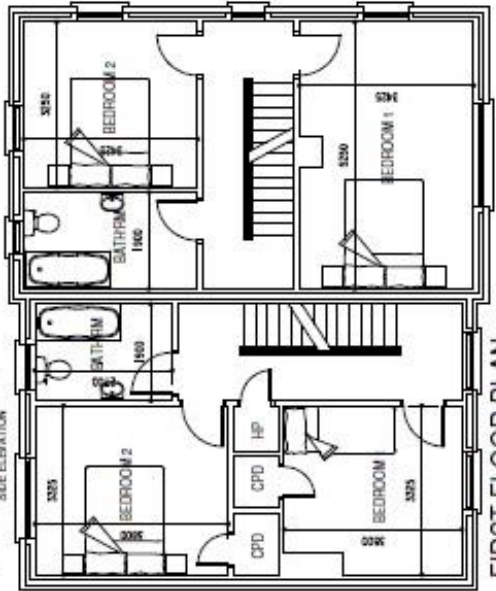

FIRST FLOOR PLAN

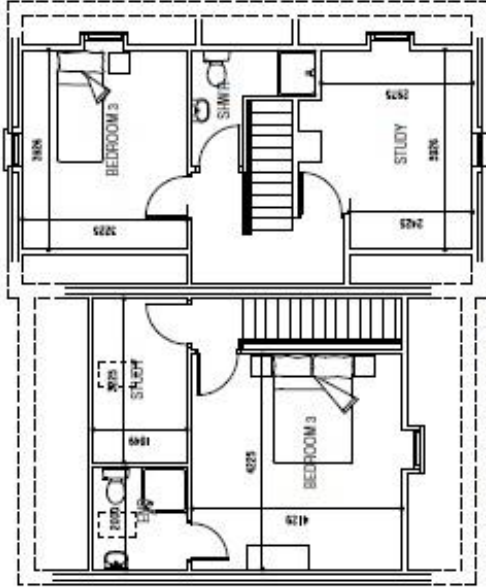

SECOND FLOOR PLAN

# HOUSE TYPE C, C2 & D1





# HOUSE TYPE C1 & D

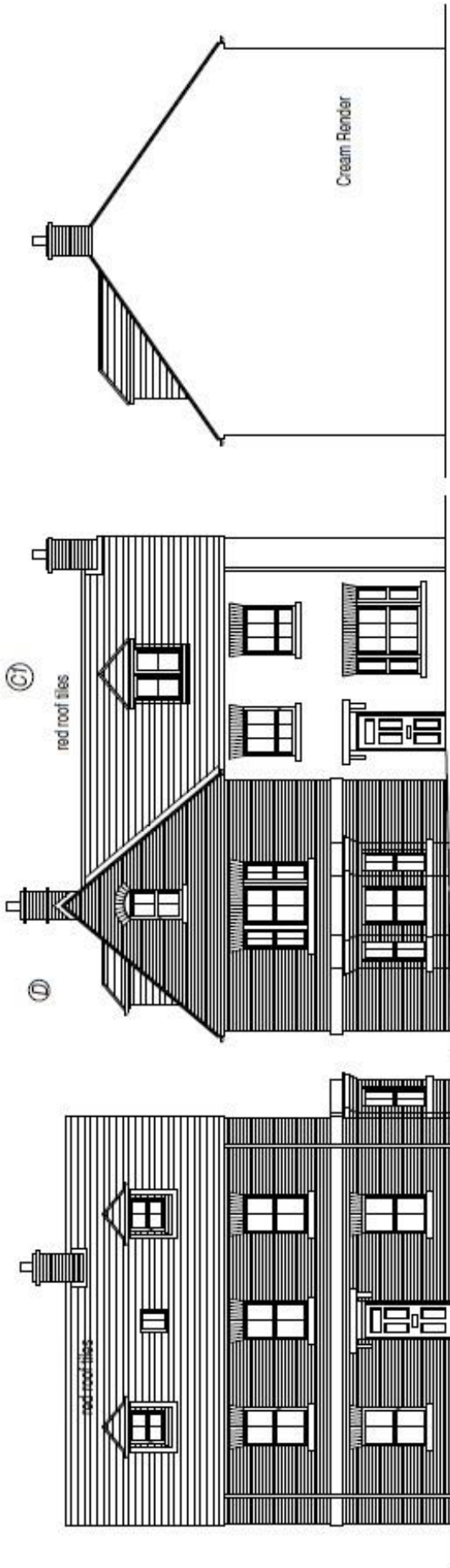

PROPOSED SIDE ELEVATION

PROPOSED FRONT ELEVATION

PROPOSED SIDE ELEVATION

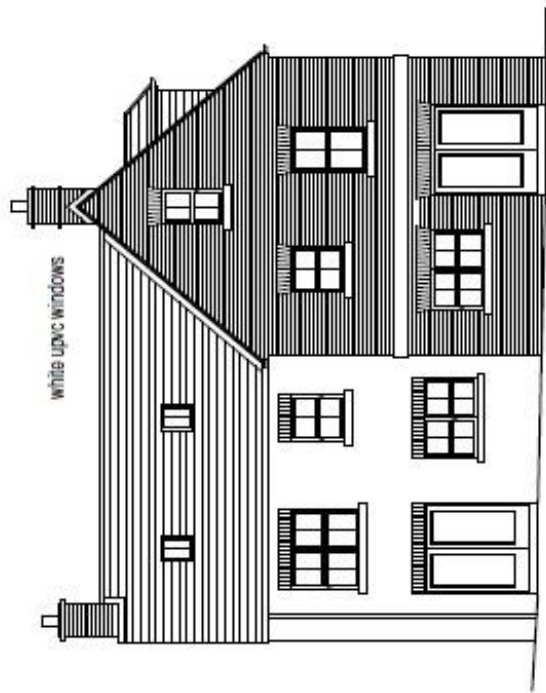

PROPOSED REAR ELEVATION

Area: 1380sqft

Area: 1250sqft

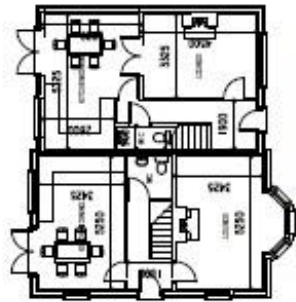

PROPOSED GROUND FLOOR PLAN



PROPOSED FIRST FLOOR PLAN

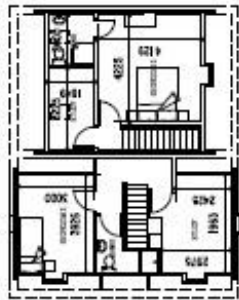

PROPOSED SECOND FLOOR PLAN

# HOUSE TYPE E1

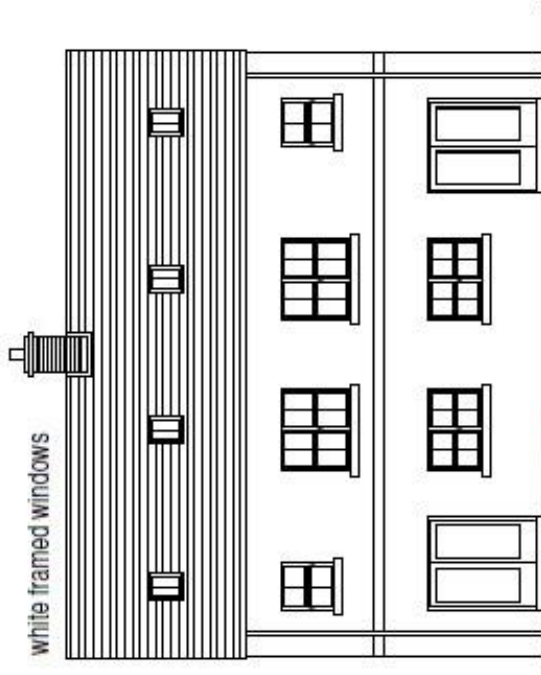
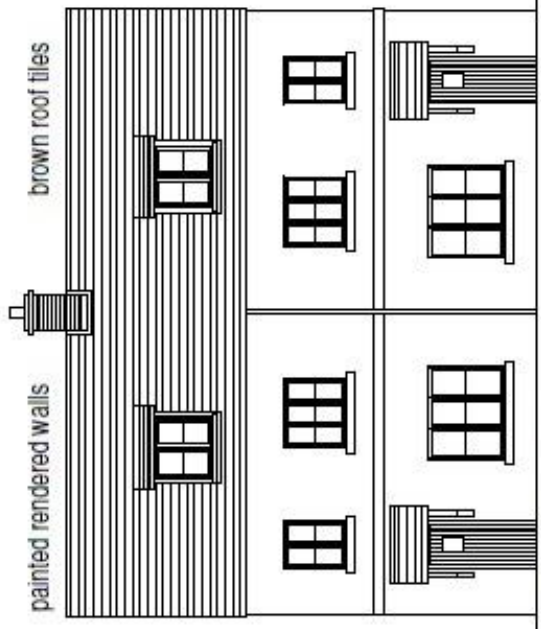

FRONT ELEVATION

REAR ELEVATION

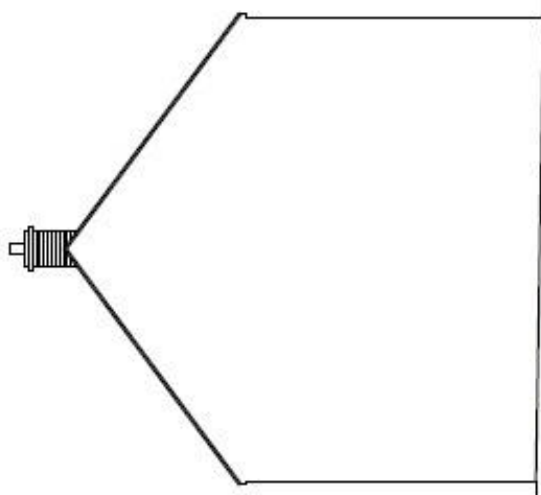

SIDE ELEVATION

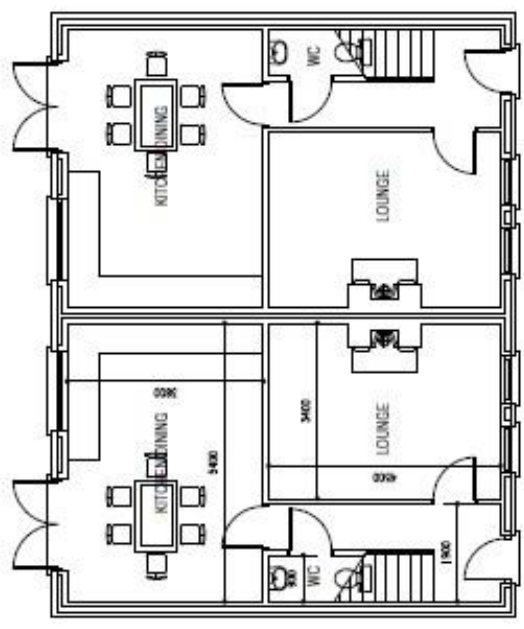

GROUND FLOOR PLAN

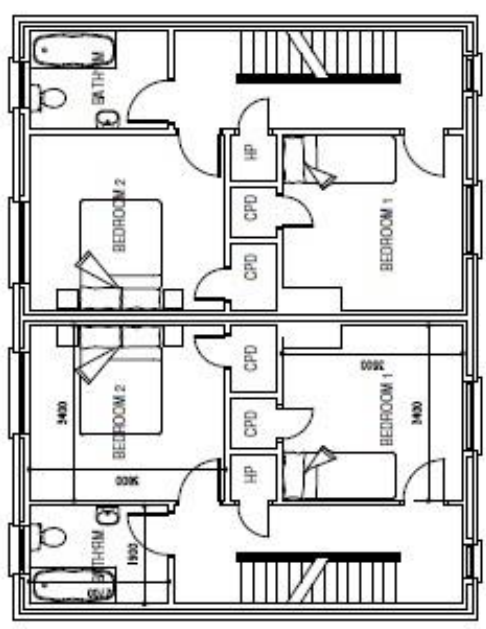

FIRST FLOOR PLAN

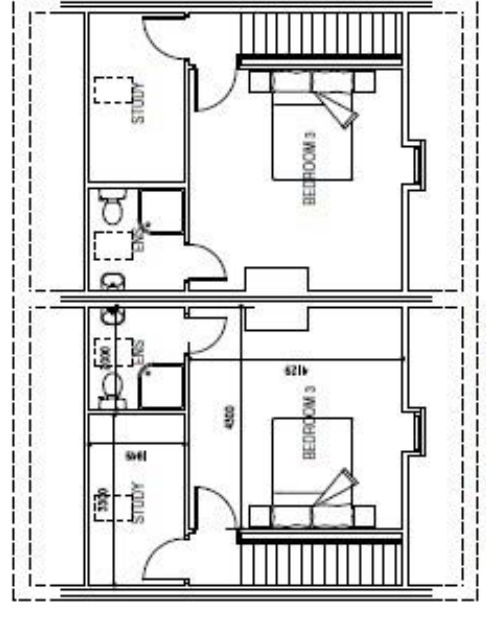

SECOND FLOOR PLAN



# HOUSE TYPE G, G1 & H



# HOUSE TYPE I

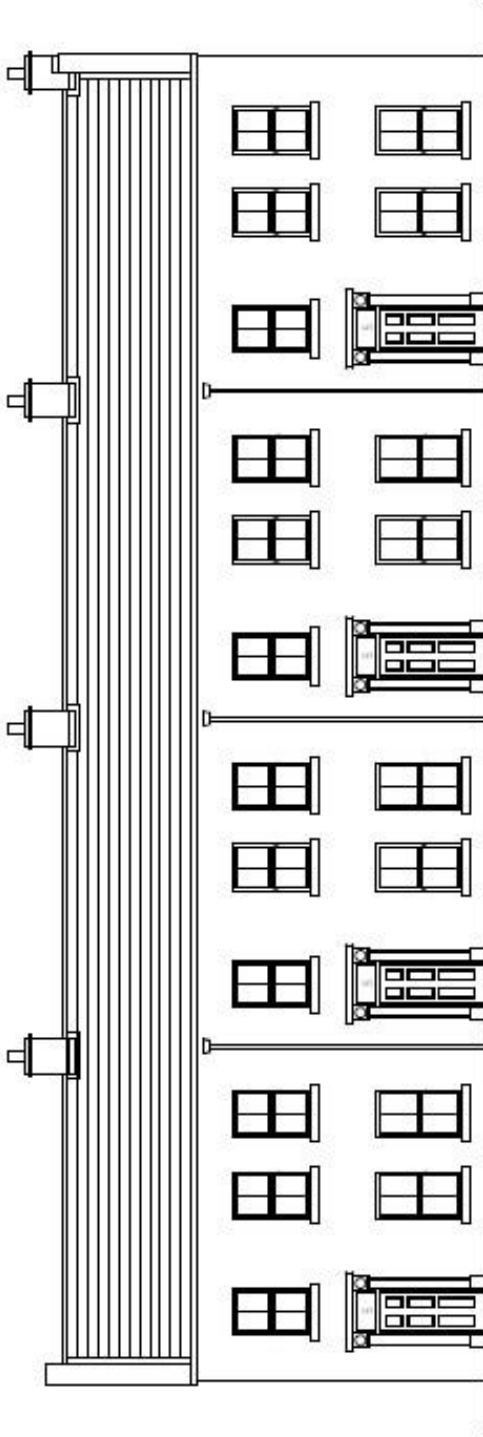

PROPOSED FRONT ELEVATION

Area: 1110sqft

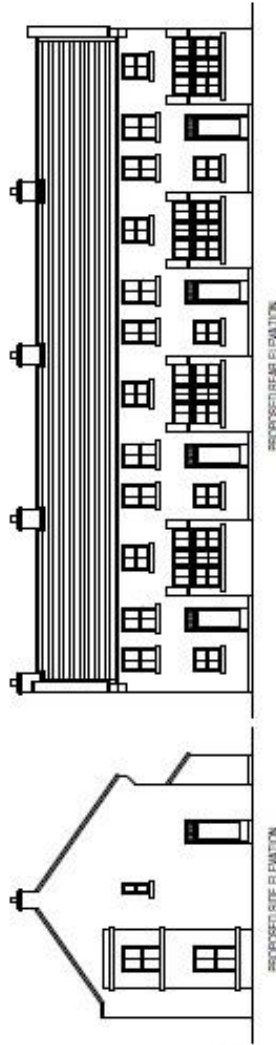

PROPOSED REAR ELEVATION



PROPOSED SIDE ELEVATION

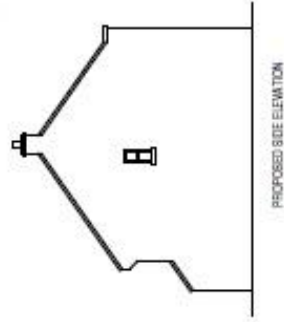

PROPOSED SIDE ELEVATION

FINISHES  
WHITE RENDERED WALLS,  
GREY ROOF TILES  
WHITE UPVC WINDOWS

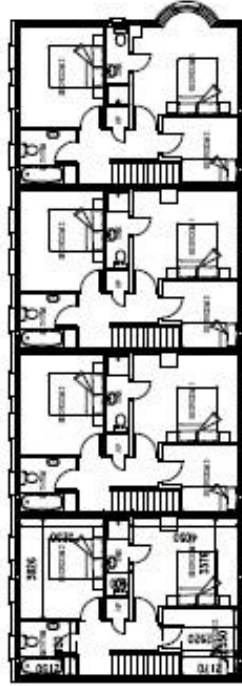

PROPOSED FIRST FLOOR PLAN

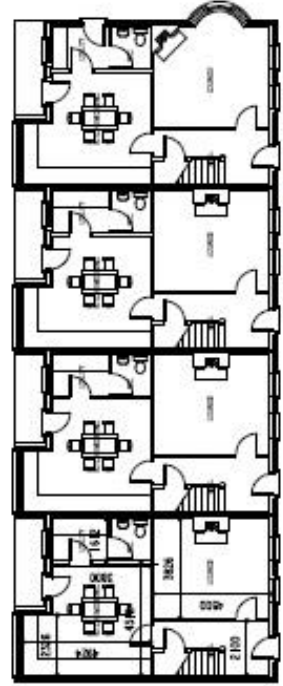

PROPOSED GROUND FLOOR PLAN

**FOR I.D. PURPOSES**

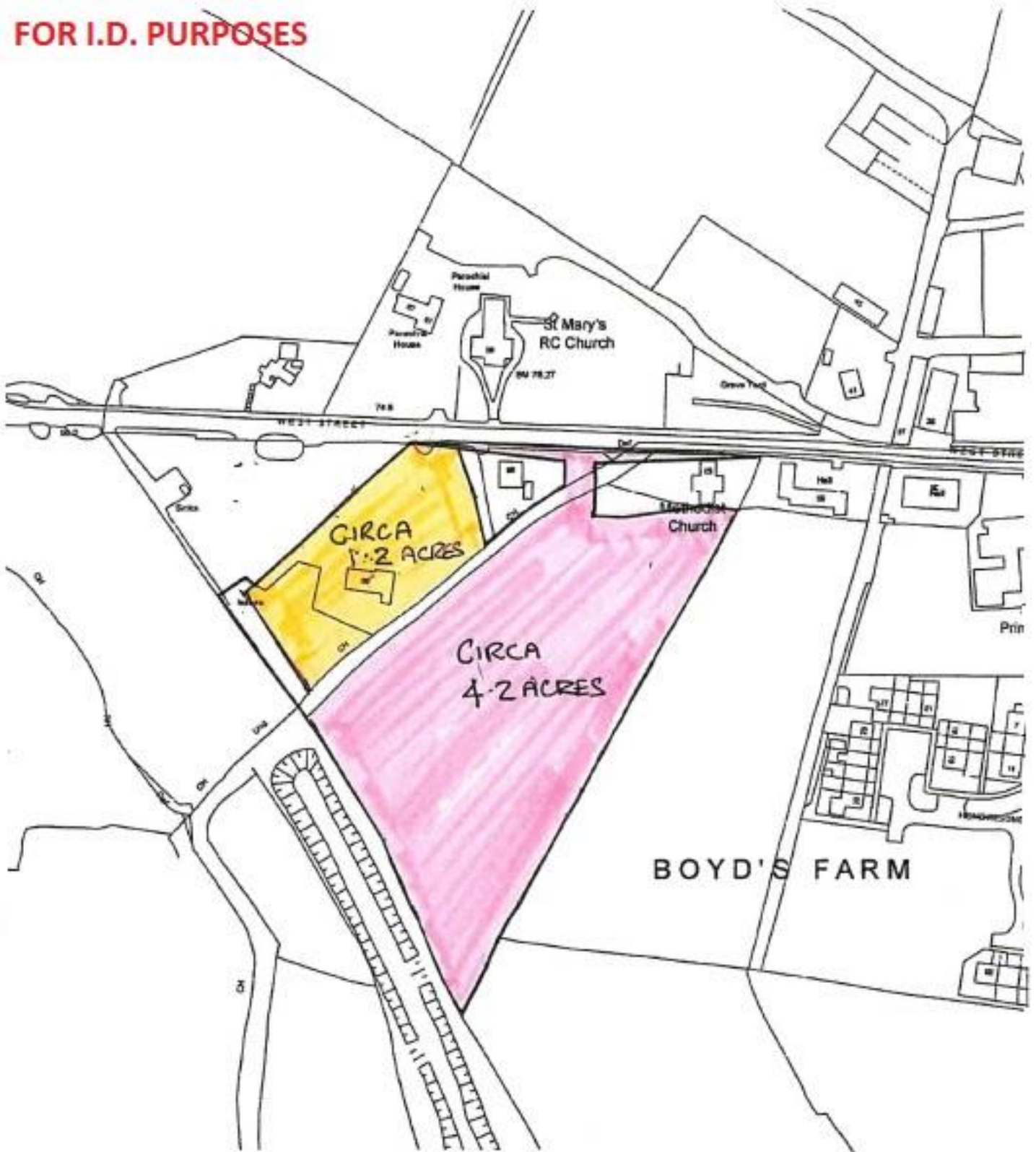

**OS PLAN:- 14205SE**



**N.B.**

Any photographs displayed or attached to brochures may have been taken with a wide angled lens. Tom Henry & Co. have not tested any equipment, apparatus, fittings or services and cannot verify that these are in working order.

**VALUATIONS:**

Should you be considering the sale of your own property we would be pleased to arrange through our office a Free Valuation and advice on selling without obligation.

**FOR FULL DETAILS & ARRANGEMENTS TO VIEW PLEASE CONTACT THE SOLE AGENT.**